

STAR
WARS

MACE WINDU™

FORCE FX LIGHTSABER™ COLLECTIBLE

Adult Collectible
89832/87991 Asst.



x3 1.5V AAA/LR03 size
BATTERIES REQUIRED

Requires 3 x 1.5V "AAA" or LR03 size alkaline batteries (not included).



PLEASE RETAIN INSTRUCTIONS FOR FUTURE REFERENCE.

WARNING!

To prevent risk of electric shock or serious injury, never disassemble the lightsaber.

- **DO NOT attempt to perform any repairs yourself.** There are no consumer repairable parts inside.
- **Never use to strike others.** This product is not intended for striking people, animals or objects. This product is not covered by warranty for damage caused by striking against hard objects.
- Never run with the lightsaber. Never use the lightsaber in total darkness.
- Always check the area around you before swinging the lightsaber to ensure you do not injure anyone or cause damage.
- Turn off the lightsaber when not in use. Never leave the lightsaber on when unattended.
- To prevent risk of electric shock or serious injury, never immerse the lightsaber in water or allow the lightsaber to become wet. Use only a soft, dry cloth to clean.
- If the blade of the lightsaber becomes cracked or damaged, stop using the lightsaber immediately.

BATTERY INSTALLATION

1. Make sure the lightsaber is OFF.
2. Unscrew pommel (end cap) counter-clockwise to expose the battery pack.
3. Completely remove the battery pack from the hilt (handle).
4. Using a Phillips/crosshead screwdriver (not included), loosen screw in battery pack sleeve (screw will remain attached to sleeve). Slide sleeve off battery pack.
5. Insert 3 x 1.5V "AAA" or LR03 size alkaline batteries in the battery pack. Make sure the batteries are correctly oriented; refer to the + and - markings as a guide.
6. To re-insert the battery pack, slide sleeve back onto pack, and tighten screw. Align the yellow arrow on the pack with the yellow triangle inside the hilt (handle). Slide it in until it stops. **DO NOT FORCE!** Replace pommel (end cap) by screwing it on clockwise.

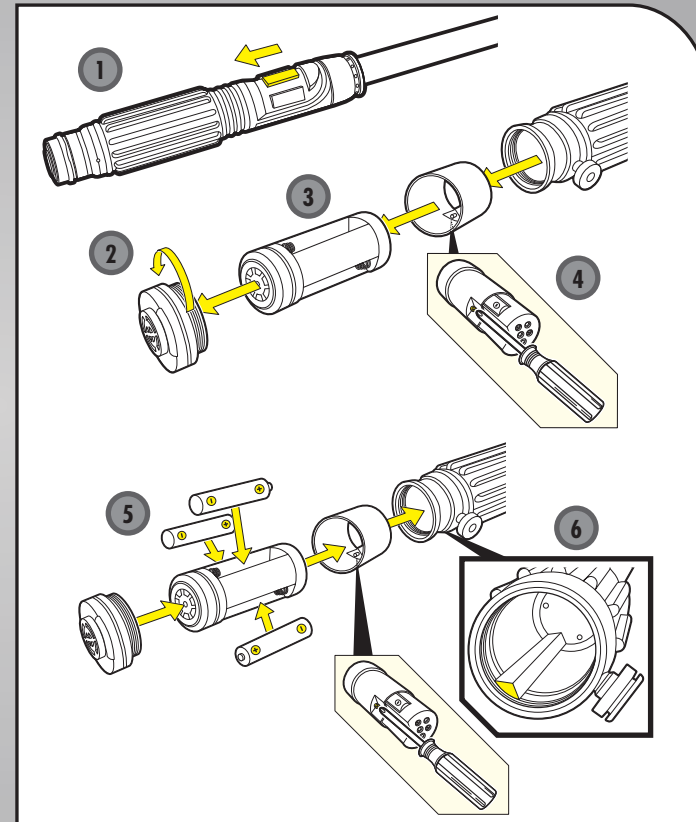

P/N 6896930000



Product and colors may vary.
© 2009 Lucasfilm Ltd. & © or TM where indicated. All rights reserved.
®* and/or TM* & © 2008 Hasbro. All Rights Reserved.
TM & © denote U.S. trademarks.

OPERATING INSTRUCTIONS

On/Off

Locate the ON/OFF switch on the control panel as shown in the diagram. To turn the lightsaber ON, slide the switch forward, away from you. To turn the lightsaber OFF, slide the switch backward, toward you.

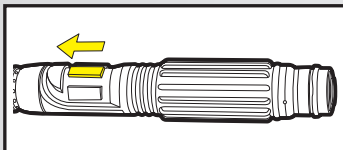

DISPLAY STAND

Assemble stand as shown.

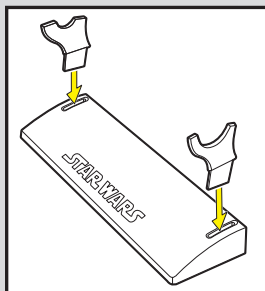

Place lightsaber on stand as shown.

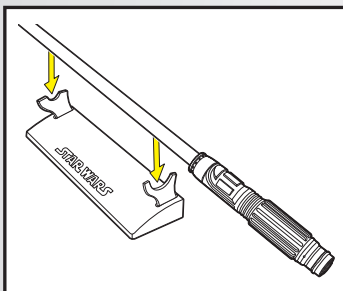

FREQUENTLY ASKED QUESTIONS

Q: Is the Force FX Lightsaber a licensed collectible?

A: Yes. The Force FX Lightsaber is a licensed collectible approved and endorsed by Lucasfilm Ltd. As a collectible, the Force FX Lightsaber is not suitable for children.

Q: Is the Force FX Lightsaber a limited edition prop replica?

A: No. Although the design of the Force FX Lightsaber is faithful to the look of the movie prop, it is not an exact replica. The hilt of the Force FX Lightsaber was made slightly larger than the actual movie prop in order to accommodate the electronics that control the light and sound effects. The Force FX Lightsaber collectibles are not limited to a pre-determined edition size; therefore, they are not classified as limited edition replicas.

Q: What is the blade on the Force FX Lightsaber made of?

A: The Force FX Lightsaber features a permanently attached polycarbonate blade. Once activated, the blade glows brightly and the replica plays back digitally recorded sound effects taken directly from the film.

Q: Is the blade on the Force FX Lightsaber removable?

A: No, the blade is not removable or retractable.

Q: How do the light and sound effects work in the Force FX Lightsaber?

A: The Force FX Lightsaber incorporates motion sensors, which sense both the motion of the blade as well as when it comes in contact with something. An on-board, multi-channel chip is programmed with digital sound effects originally created for the movie by Skywalker Sound. The Force FX Lightsaber replicates the following sound effects:

- Power-up
- Idle hum
- Swing (with pitch change)
- Clash
- Power-down

Q: How long should the light in the Force FX Lightsaber last?

A: It should run for several hours on a fresh set of batteries. The electronics, if cared for properly, should last for several thousand hours of use. Replace the batteries whenever the performance begins to change, such as reduced brightness or volume.

Q: Can I use my Force FX Lightsaber for dueling?

A: No. This product should not be used to strike other people or animals. Although the blade is very durable, it should never be used for fighting or dueling. The Force FX Lightsaber was produced to be a collectible.

Q: Sometimes I see a dark spot in the middle of the blade. Is there something wrong with the lightsaber?

A: No. The dark area is actually a result of the design. All the Force FX Lightsabers are handmade and as a result, this slightly dark area at the middle of the blade is normal. This does not affect the performance of the lightsaber in any way.

IMPORTANT: BATTERY INFORMATION



CAUTION:

1. As with all small batteries, the batteries used with this product should be kept away from small children who still put things in their mouths. If they are swallowed, promptly see a doctor and have the doctor phone (202) 625-3333 collect. If you reside outside the United States, have the doctor call your local poison control center.
2. Always follow the instructions carefully. Use only batteries specified and be sure to insert them correctly by matching the + and - polarity markings with alkaline batteries.
3. Do not mix old batteries and new batteries or standard (carbon-zinc) with alkaline batteries.
4. Remove exhausted or dead batteries from the product.
5. Remove batteries if product is not to be played with for a long time.
6. Do not short-circuit the supply terminals.
7. Should this product cause, or be affected by, local electrical interference, move it away from other electrical equipment. Reset (switching off and back on again or removing and re-inserting batteries) if necessary.
8. RECHARGEABLE BATTERIES: Do not mix these with any other types of batteries. Always remove from the product before recharging. Recharge batteries under adult supervision. **DO NOT RECHARGE OTHER TYPES OF BATTERIES.**

FCC Statement:

This device complies with part 15 of the FCC Rules. Operation is subject to the following two conditions: (1) This device may not cause harmful interference, and (2) this device must accept any interference received, including interference that may cause undesired operation.

This equipment has been tested and found to comply with the limits for a Class B digital device, pursuant to part 15 of the FCC Rules. These limits are designed to provide reasonable protection against harmful interference in a residential installation. This equipment generates, uses and can radiate radio frequency energy, and, if not installed and used in accordance with the instructions, may cause harmful interference to radio communications. However, there is no guarantee that interference will not occur in a particular installation. If this equipment does cause harmful interference to radio or television reception, which can be determined by turning the equipment off and on, the user is encouraged to try to correct the interference by one or more of the following measures:

- Reorient or relocate the receiving antenna.
- Increase the separation between the equipment and receiver.
- Consult the dealer or an experienced radio/TV technician for help.

CAUTION: Changes or modifications not expressly approved by the party responsible for compliance could void the user's authority to operate the equipment.